

DATA SHEET – PD0740

22kw HEATER UNIT

Overview

Build Specification

Weight	160kg
Heater Type	2x10.8 immersion heater
Voltage	415V – 3 phase
Maximum Operating Pressure	25 Bar
Temperature Reading	Inlet/outlet
Connections	2" BSPP inlet/outlet
Temperature Controller	Adjustable Thermostat
Electrical Connection	10m cable equipped with 63 amp plug
Lifting	Four lifting points and tynes pocket

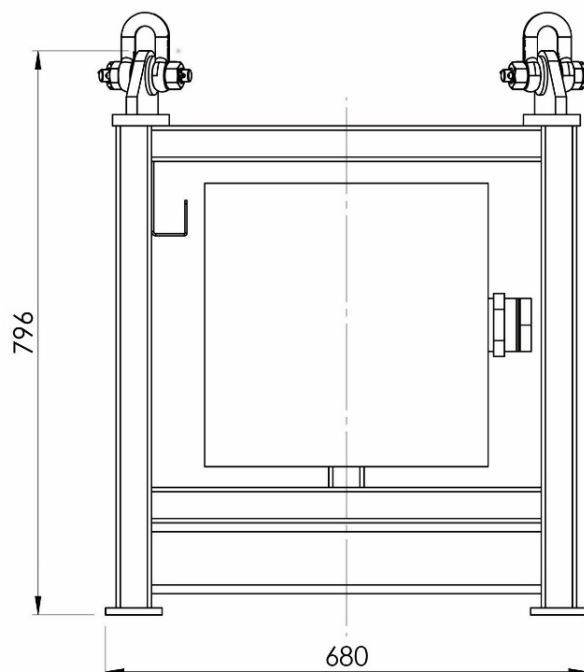

Operating Specifications

Fluid Types Mineral Based Oils

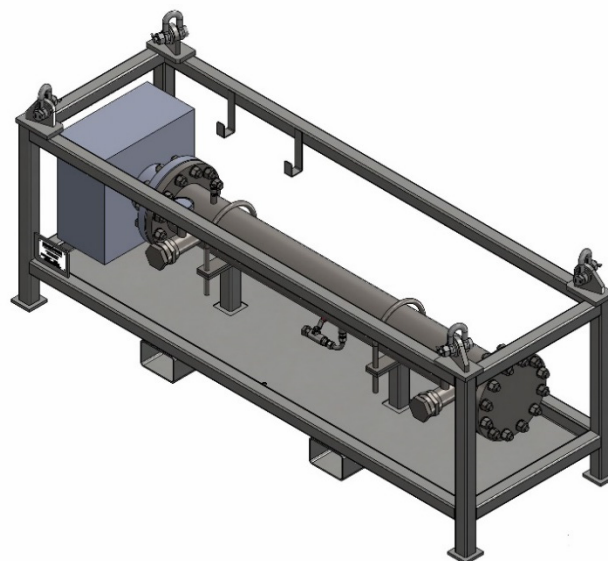
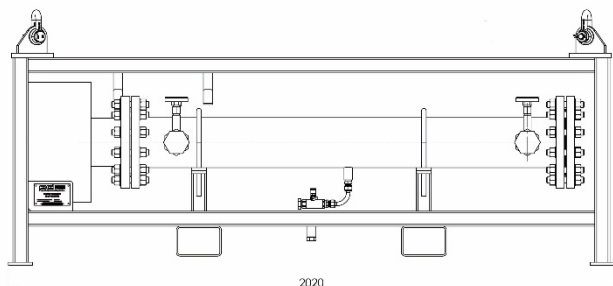

ABOUT PRESSURE DYNAMICS

Pressure Dynamics is an engineering and services contractor specialising in hydraulic and lifting solutions.

Our team of highly skilled project managers, engineers and technicians are committed to collaborating with our clients in providing innovative, quality-assured services and products that deliver superior function, reliability and safety.

When we deliver, we focus on:



RELIABILITY

Optimising equipment and system performance - to maximise your ROI.



PRODUCTIVITY

Maximising operational reliability of assets and equipment safely and cost-effectively.



INNOVATIVE SOLUTIONS

Developing creative, fit-for-purpose solutions to meet our client's true needs and objectives.



RISK MANAGEMENT

Delivering and maintaining quality, cost-effective and safe equipment and assets while mitigating risk.



MUTUAL SUSTAINABILITY

Delivering skill, knowledge and understanding through our documentation, user-intuitive products and training services.

Market sectors we operate in:



Oil & Gas



Mining



Marine



Defence



Infrastructure



Power & Utilities

Our location network



Abu Dhabi, UAE
Ghana, W Africa

